

# SPECIFICATIONS

<b>Customer</b>	
<b>Product Name</b>	<b>Mini Molded Chip Power Inductor</b>
<b>Lineprinting Part Number</b>	<b>LMSH2012081R0MTA</b>
<b>Customer Part Number</b>	

<b>Approved By</b>	<b>Checked By</b>	<b>Issued By</b>

**【For Customer approval Only】**

Date: \_\_\_\_\_

Qualification Status:    Full            Restricted            Rejected

<b>Approved By</b>	<b>Verified By</b>	<b>Checked By</b>

Comments:

**【Version change history】**

versions	Effective Date	Changed Contents	Change Reasons	Approved By
A01	Oct.28.2023	New release	/	
A02	May.29.2024	Update Format	/	
A03	Mar.05.2025	Update Format	/	

# LMSH2012081R0MTA of Mini Molded Chip Power Inductor

## 1. Product Description

The main materials of moulded inductance include soft magnetic powder, coil and electrode pin. The coil and electrode pin are placed in soft magnetic powder for pressing and forming, and then solidified to get the moulded inductance. The coil is located inside the inductance blank formed by soft magnetic powder. Molded inductance has the advantages of magnetic circuit closure, anti-electromagnetic interference, high installation density and especially suitable for SMT process. It is mainly used as energy storage or filter in electronic circuits.

## 2. Key Features

- Metal material for large current and low loss Closed
- Magnetic circuit design reduces leakage flux
- Super low resistance, ultra high current rating
- Halogen free, RoHS compliant

## 3. Typical Application

- PDA, notebook, Smart phone, and server applications
- Closed magnetic circuit design reduces leakage flux
- Battery powered devices
- DC/DC converters in distributed power systems

## 4. Outline Dimensions

1) Dimensions See Fig.4-1 and recommended PCB pattern See Fig.4-2 and Table 4-1.

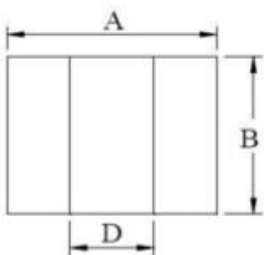

Fig 4-1

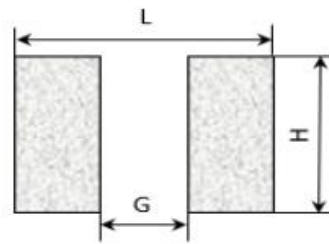

Fig 4-2

Table 4-1

Unit: mm

Type	A	B	C	D	L	G	H
201208	2.0±0.2	1.2±0.2	0.8Max	0.6Typ	2.1	0.5	1.3

## 5. Specifications

Electrical Characteristics Part Number	L	L Test Freq.	DC Resistance		Saturation Current (Isat)		Temperature Rise Current (Irms)	
			Typ	Max	Typ.	Max.	Typ.	Max.
Unit	μH	MHz	mΩ	mΩ	A	A	A	A
LMSH2012081R0MTA	1.0	1	46.0	50.0	3.5	3.3	3.5	3.2

\* : If you require another part number please contact with us.

\*\* : Inductance Tolerance  $\pm 20\%$

- 1) All test data is referenced to 25°C ambient
- 2) Test Condition: 1MHz, 1.0Vrms
- 3) Idc : DC current (A) that will cause an approximate  $\Delta T$  of 40°C
- 4) Isat : DC current (A) that will cause L0 to drop approximately 30%
- 5) Operating Temperature Range -40°C to + 125°C
- 6) The part temperature (ambient + temp rise) should not exceed 125°C under the worst case operating conditions. Circuit design, component placement, PCB trace size and thickness, airflow and other cooling provision all affect the part temperature. Part temperature should be verified in the end application.
- 7) The rated current as listed is either the saturation current or the heating current depending on which value is lower
- 8) Rated Voltage Max. 20V

### ■ Current Characteristics

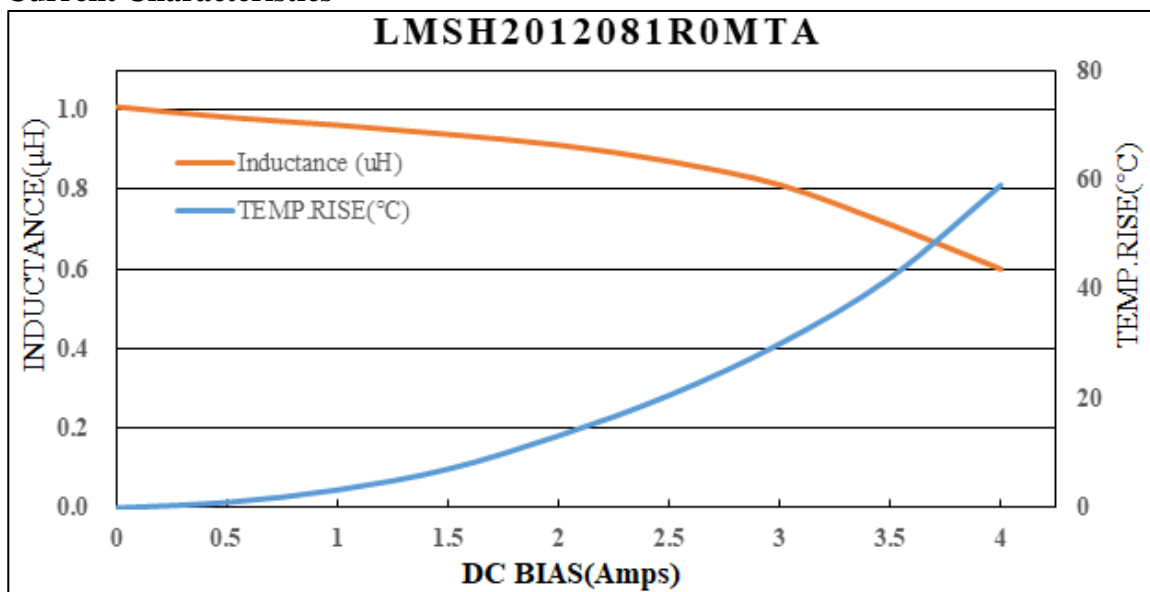

## 6. Reliability Test

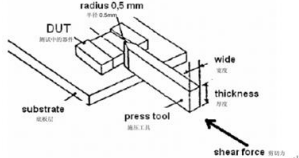
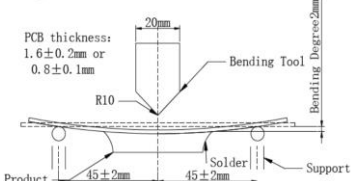
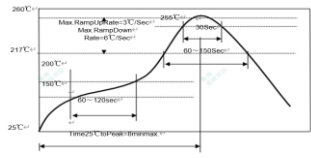
Items	Requirements	Test Methods and Remarks
6.1 Solderability	1. The appearance shows no obvious damage. 2. The coverage area of the new solder on the electrode surface is > 95%.	1. Solder: Sn - free Ag(3.0 - 4.0)Cu(0.5 - 1.0); 2. Solder temperature: 245±5°C; 3. Immersion time: 3±1 second.
6.2 Terminal Strength	1. The sample shall not fall off the test board. 2. There should be no disconnection of the leads or signs of cracks on the product matrix. 3. The inductance value change shall not exceed ±10%.	1. Solder the test samples onto the test board using reflow soldering. Push perpendicular to the side of the sample at a speed of 30mm/min until 5N is reached. 2. Duration: 10 ± 1 seconds in the direction shown in the figure. 3. The R - radius of the push - head is 0.5mm. 
6.3 Bending	1. The sample must not drop off the test board. 2. There should be no disconnection of the lead - out terminals and no signs of cracks on the product matrix.	1. Solder the test samples onto the test board using reflow soldering. Apply force in the specified direction until the bending degree of the test board reaches 2mm. 2. PCB size: 100×40×1.0 (or 0.8mm) mm. 3. Bending duration: 30s. 4. Test rate: 0.5mm/s. 
6.4 Reflow	1. The appearance shows no obvious mechanical damage. 2. The change in inductance value does not exceed ±10%.	Max.260°C, for 3 times. 
6.5 Long - term humid heat	1. The appearance should have no hidden cracks, rust, or excessive glue. 2. The change in inductance value should not exceed ±10%.	1. Temperature: 60°C. 2. Humidity: 95%RH. 3. Time: 1000H +24/-0 hours. 4. Test after standing for 1H.
6.6 Dropping	1. There should be no obvious damage to the appearance. 2. The change in inductance value should not exceed ±10%.	1. Solder the test samples onto the test boards using reflow soldering, then place them into the drop - test boxes. 2. Drop the boxes from a height of 1 meter onto a marble floor. 3. Drop the boxes onto each of the 6 faces three times, for a total of 18 drops. 4. Counterweight: 250g ± 20g.
6.7 Long - term high temperature and high humidity	1. There should be no hidden cracks, rust, glue overflow or obvious damage on the product surface. 2. The variation of inductance value should not exceed ±10%.	1. Temperature: 85±2°C. 2. Humidity: 85±5%. 3. Duration: 1000H +24/0 hours. 4. Test after standing for 1H.

6.8 Low temperature storage	- 1.The surface of the product shall be free of hidden cracks, rust, glue overflow and obvious damage. 2.The change in inductance value shall not exceed $\pm 10\%$ .	1. Temperature: $-40\pm 2^{\circ}\text{C}$ . 2. Time: 1000 +24/-0 hours. 3. Test after standing for 1 hour.
6.9 High temperature storage	- 1.The surface of the product shall be free of hidden cracks, rust, glue overflow and obvious damage. 2.The change in inductance value shall not exceed $\pm 10\%$ .	1. Temperature: $125\pm 2/-0^{\circ}\text{C}$ . 2. Time: 1000+24/-0 hours. 3. Test after standing for 1 hour.
6.10 Long - term durability	- 1.The surface of the product shall be free of hidden cracks, rust, glue overflow and obvious damage. 2.The change in inductance value shall not exceed $\pm 10\%$ .	1. Temperature: $85 \pm 2^{\circ}\text{C}$ 2. Duration: 1000 + 24 / -0 hours 3. Applied current: Rated current 4. Conduct the test after leaving it to stand for 1 hour.
6.11 Thermal Shock	1.The surface of the product shall be free of hidden cracks, rust, glue overflow and obvious damage. 2.The change in inductance value shall not exceed $\pm 10\%$ .	1. $-55\pm 0/-5^{\circ}\text{C}$ for $30\pm 3$ minutes $\rightarrow$ room temperature within 5 minutes $\rightarrow$ $125\pm 5/-0^{\circ}\text{C}$ for $30\pm 3$ minutes $\rightarrow$ room temperature 2. Conversion time: 5 minutes Max 3. Cycles: 100 4. Conduct the test after standing for 1 hour
6.12 Vibration	1. The product should not have any parts falling off or cracks. 2. The variation of the inductance value should not exceed $\pm 10\%$ .	1. The test samples are soldered onto the test board by reflow soldering. 2. Acceleration: 5g 3. Sweep speed: 20 min/cycle 4. Cycles: 12 cycles per axis (X, Y, Z), 36 in total 5. Frequency: 10 - 2000H
6.13 Humid heat load (60/95%RH+ loading)	1.The surface of the product shall be free of hidden cracks, rust, glue overflow and obvious damage. 2.The change in inductance value shall not exceed $\pm 10\%$ .	1. Temperature: $60^{\circ}\text{C}$ 2. Humidity: 95%RH 3. Applied Current: Rated current 4. Duration: 1000H +24/-0 hours 5. Conduct the test after leaving it standing for 1 hour.

## 7. Packaging and Storage

### 7.1 Tape packaging dimensions

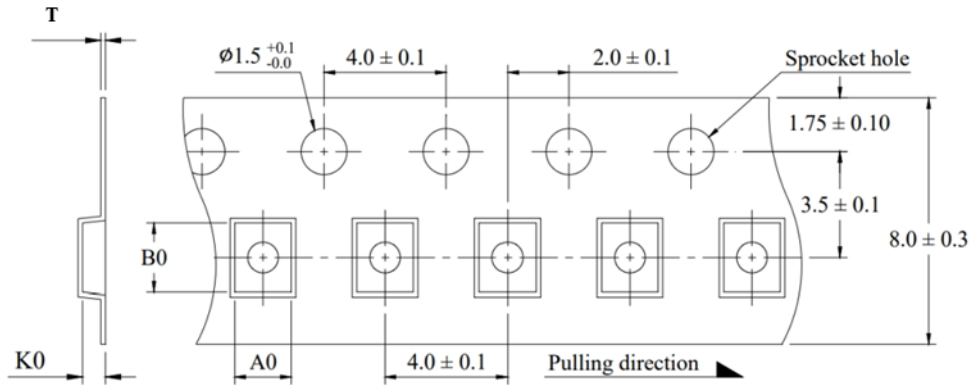

Dimensions Code (mm)				Units/Reel
A0	B0	K0	T	
$1.55 \pm 0.05$	$2.35 \pm 0.05$	$0.95 \pm 0.05$	$0.22 \pm 0.05$	3K

### 7.2 Tape Direction

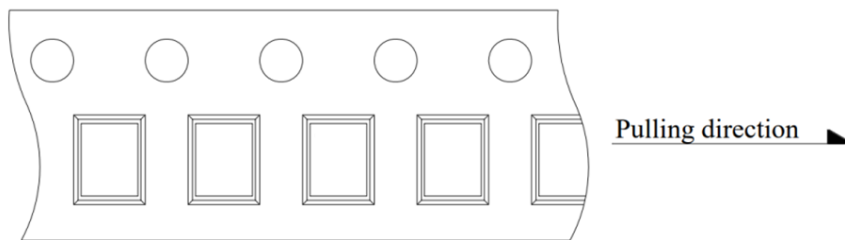

### 7.3 Reel Dimensions (Unit: mm)

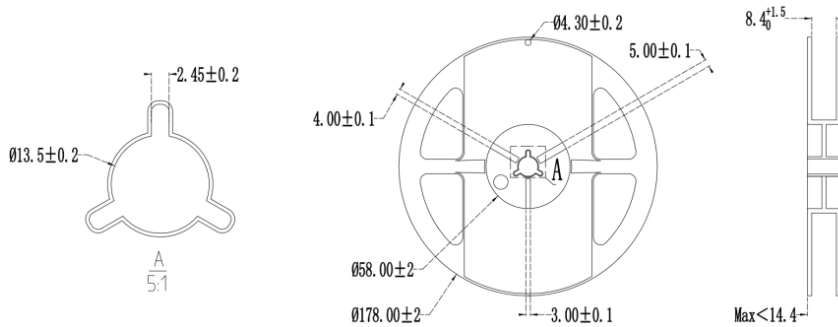

### 7.4 Peel force of top cover tape

The peel speed shall be about 300 mm/minute.

The peel force of top cover tape shall be between 0.1 to 0.7N.

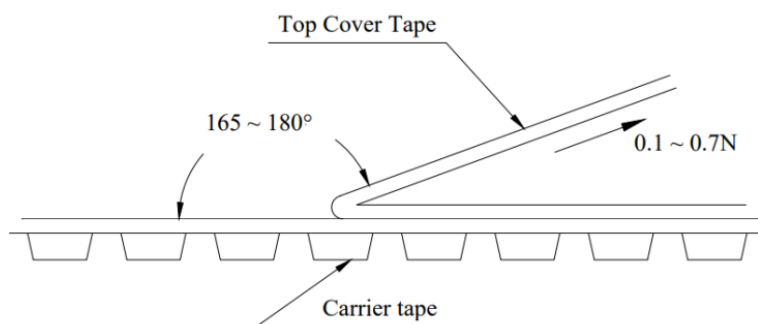

### 7.5 Storage

- 1) To maintain the solderability of terminal electrodes and to keep the packing material in good condition, temperature and humidity in the storage area should be controlled.
- 2) Recommended conditions: -10°C~40°C, 70% RH (Max.)
- 3) Even under ideal storage conditions, solderability of products electrodes may decrease as time passes.

For this reason, product should be used with one year from the time of delivery.

- 4) In case of storage over 6 months, solderability shall be checked before actual usage.

### 8. Reflow Profile

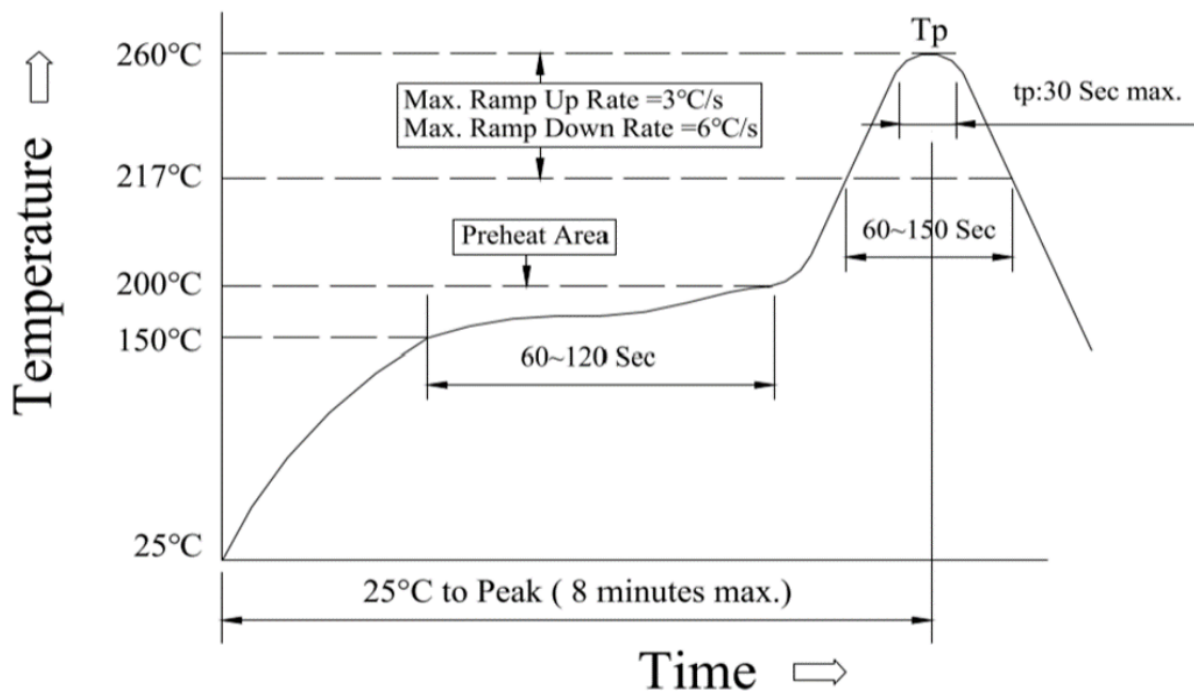

(1) Reflow Soldering Method :

Reflow Soldering	$T_p$ :255~260°C	Max.30 seconds ( $t_p$ )
	217°C	60~150 seconds
Pre-Heat	150 ~ 200°C	60~120 seconds
Time 25°C to peak temperature	8 minutes max	

(2) Soldering iron Method : 350±5°C max. 3 seconds