

## CSD95485RWJ 同步降压 NexFET™智能功率级

### 1 特性

- 具有 75A 持续工作电流能力
- 30A 电流下系统效率超过 95%
- 工作频率高（高达 1.25MHz）
- 二极管仿真功能
- 温度补偿双向电流感应
- 模拟温度输出
- 故障监控
- 兼容 3.3V 和 5V PWM 信号
- 三态 PWM 输入
- 集成自举开关
- 用于击穿保护的经优化死区时间
- 高密度 5mm × 6mm QFN 封装
- 超低电感封装
- 系统已优化的 PCB 空间占用
- 耐热增强型顶部散热
- 符合 RoHS 标准 – 无铅端子镀层
- 无卤素

### 2 应用

- 多相同步降压转换器
  - 高频率应用
  - 高电流、低占空比应用
- POL 直流/直流转换器
- 存储器和显卡
- 台式机和服务器 VR12.x/VR13.x V-core 同步降压转换器

### 3 说明

CSD95485RWJ NexFET™功率级是经过高度优化的设计，用于高功率、高功率密度场合的同步降压转换器。这款产品集成了驱动器 IC 和功率 MOSFET 来完善功率级开关功能。该组合采用 5mm × 6mm 小型封装，可实现高电流、高效率以及高速切换功能。它还集成了准确电流检测和温度感测功能，以简化系统设计并提高准确度。此外，PCB 封装已经过优化，可帮助减少设计时间并简化总体系统设计。

#### 器件信息(1)

器件	介质	数量	封装	配送
CSD95485RWJ	13 英寸卷带	2500	QFN 5.00mm × 6.00mm 封装	卷带 封装
CSD95485RWJT	7 英寸卷带	250		

(1) 如需了解所有可用封装，请参阅数据表末尾的可订购产品附录。

#### 应用图表

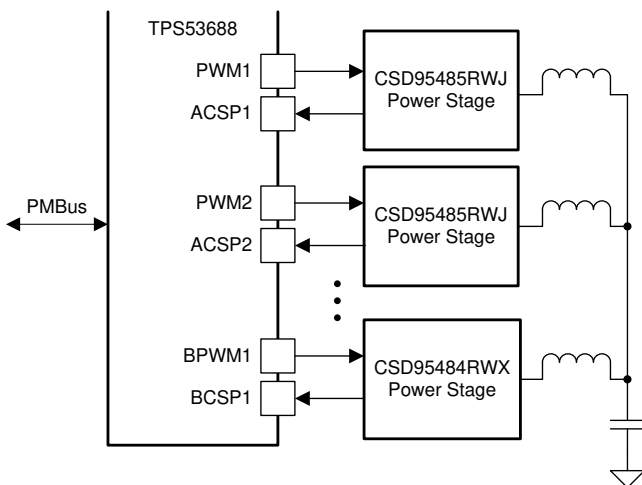

#### 典型功率级效率与功率损耗

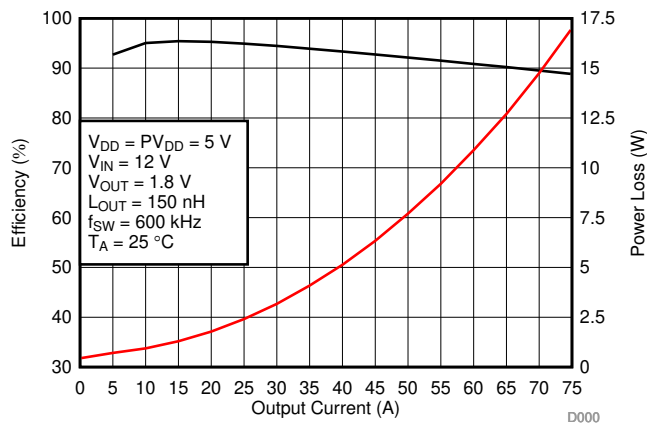

## 目录

<ul style="list-style-type: none"> <li>1 特性 ..... 1</li> <li>2 应用 ..... 1</li> <li>3 说明 ..... 1</li> <li>4 修订历史记录 ..... 2</li> <li>5 <b>Pin Configuration and Functions</b> ..... 3</li> <li>6 <b>Specifications</b> ..... 4           <ul style="list-style-type: none"> <li>6.1 Absolute Maximum Ratings ..... 4</li> <li>6.2 ESD Ratings ..... 4</li> <li>6.3 Recommended Operating Conditions ..... 4</li> </ul> </li> </ul>	<ul style="list-style-type: none"> <li>6.4 Thermal Information ..... 5</li> <li>7 <b>Application Schematic</b> ..... 6</li> <li>8 器件和文档支持 ..... 7           <ul style="list-style-type: none"> <li>8.1 商标 ..... 7</li> <li>8.2 静电放电警告 ..... 7</li> <li>8.3 Glossary ..... 7</li> </ul> </li> <li>9 机械、封装和可订购信息 ..... 8           <ul style="list-style-type: none"> <li>9.1 机械制图 ..... 8</li> <li>9.2 推荐 PCB 焊盘图案 ..... 9</li> <li>9.3 建议模版开孔 ..... 10</li> </ul> </li> </ul>
--	---

## 4 修订历史记录

日期	修订版本	说明
2020 年 3 月	*	初始发行版。

## 5 Pin Configuration and Functions

**RWJ Package  
41-Pin QFN  
Top View**

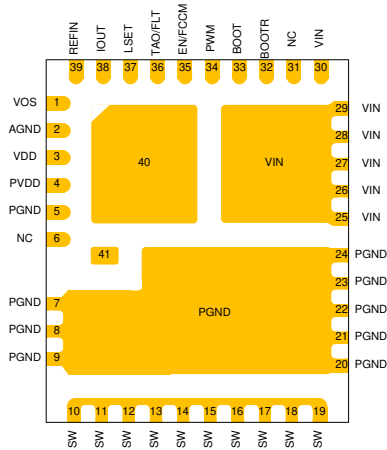

**Pin Functions**

PIN		DESCRIPTION
NAME	NUMBER	
VOS	1	Output voltage sensing pin for the internal current sensing circuitry.
AGND	2	This pin is internally connected to PGND.
VDD	3	Supply voltage for internal circuitry. This pin should be bypassed directly to pin 2.
PVDD	4	Supply voltage for gate drivers. This pin should be bypassed to PGND.
PGND	5	Power ground.
NC	6	Not connected. This pin needs to be left floating in application.
PGND	7-9	Power ground.
VSW	10-19	Phase node connecting the HS MOSFET source and LS MOSFET drain – pin connection to the output inductor.
PGND	20-24	Power ground.
VIN	25-30	Input voltage pin. Connect input capacitors close to this pin.
NC	31	Not connected. This pin needs to be left floating in application.
BOOTR	32	Return path for HS gate driver. It is connected to VSW internally.
BOOT	33	Bootstrap capacitor connection. Connect a minimum 0.1- $\mu$ F, 16-V, X5R ceramic capacitor from BOOT to BOOTR pins. The bootstrap capacitor provides the charge to turn on the control FET. The bootstrap diode is integrated.
PWM	34	Tri-state input from external controller. Logic low sets control FET gate low and sync FET gate high. Logic high sets control FET gate high and sync FET gate low. Both MOSFET gates are set low if PWM stays in Hi-Z for greater than the tri-state shutdown holdoff time ( $T_{3HT}$ ).
EN/FCCM	35	This dual function pin either enables the diode emulation function or can be used as a simple enable for the device. When this pin is driven into the tri-state window and held there for more than the tri-state holdoff time, diode emulation mode is enabled for sync FET. When the pin is high, device operates in forced continuous conduction mode. When the pin is low, both FETs are held off. An internal resistor pulls this pin low if left floating.
TAO/FLT	36	Temperature amplifier output. Reports a voltage proportional to the IC temperature. An ORing diode is integrated in the IC. When used in a multi-phase application, a single wire can be used to connect the TAO pins of all the ICs. Only the highest temperature will be reported. TAO will be pulled up to 3.3 V if thermal shutdown LSOC or HSS detection circuit is tripped.
LSET	37	A resistor from this pin to PGND pin sets the inductor value for the internal current sensing circuitry.
IOUT	38	Output of current sensing amplifier. $V(IOUT) - V(REFIN)$ is proportional to the phase current.
REFIN	39	External reference voltage input for current sensing amplifier.
PGND	40	Power ground.
NC	41	Not connected. This pin needs to be left floating in application.

## 6 Specifications

### 6.1 Absolute Maximum Ratings

 $T_A = 25^\circ\text{C}$  (unless otherwise noted)<sup>(1)</sup>

	MIN	MAX	UNIT
$V_{IN}$ to $P_{GND}$	-0.3	20	V
$V_{IN}$ to $V_{SW}$	-0.3	20	V
$V_{IN}$ to $V_{SW}$ (10 ns)		23	V
$V_{SW}$ to $P_{GND}$	-0.3	20	V
$V_{SW}$ to $P_{GND}$ (10 ns)		23	V
$V_{SW}$ to $P_{GND}$ (10 ns)	-7		V
$V_{DD}$ to $P_{GND}$	-0.3	7	V
EN/FCCM, TAO/FLT, LSET to $P_{GND}$ <sup>(3)</sup>	-0.3	$V_{DD} + 0.3$	V
IOUT, VOS, PWM to $P_{GND}$	-0.3	7	V
REFIN to $P_{GND}$	-0.3	3.6	V
BOOT to $P_{GND}$	-0.3	30	V
BOOT to BOOT_R <sup>(3)</sup>	-0.3	$V_{DD} + 0.3$	V
$T_J$ Operating junction temperature	-55	150	°C
$T_{stg}$ Storage temperature	-55	150	°C

- (1) Stresses beyond those listed under *Absolute Maximum Ratings* may cause permanent damage to the device. These are stress ratings only, and functional operation of the device at these or any other conditions beyond those indicated in the *Recommended Operating Conditions* is not implied. Exposure to absolute-maximum-rated conditions for extended periods may affect device reliability.
- (2)  $I_{LOAD}$  is defined as the current flowing out of the VSW pins.
- (3) Should not exceed 7 V.

### 6.2 ESD Ratings

	VALUE	UNIT
$V_{(ESD)}$ Electrostatic discharge	Human-body model (HBM)	±2000
	Charged-device model (CDM)	±500
		V

### 6.3 Recommended Operating Conditions

 $T_A = 25^\circ\text{C}$  (unless otherwise stated)

	MIN	MAX	UNIT
$V_{DD}$ Driver supply voltage	4.5	5.5	V
$PV_{DD}$ Gate drive voltage	4.5	5.5	V
$V_{IN}$ Input supply voltage <sup>(1)</sup>	4.5	16	V
$V_{OUT}$ Output voltage		5.5	V
PWM to $P_{GND}$		$V_{DD} + 0.3$	V
$I_{OUT}$ Continuous output current	$V_{IN} = 12\text{ V}$ , $V_{DD} = 5\text{ V}$ , $PV_{DD} = 5\text{ V}$ , $V_{OUT} = 1.2\text{ V}$ , $f_{SW} = 500\text{ kHz}$ <sup>(2)</sup>		75
$I_{OUT-PK}$ Peak output current <sup>(3)</sup>			105
$f_{SW}$ Switching frequency	$C_{BST} = 0.1\ \mu\text{F}$ (min), $V_{OUT} = 2.5\text{ V}$ (max)		1250
On-time duty cycle	$f_{SW} = 1\text{ MHz}$		85%
Minimum PWM on-time	20		ns
Operating junction temperature	-40	125	°C

- (1) Operating at high  $V_{IN}$  can create excessive AC voltage overshoots on the switch node ( $V_{SW}$ ) during MOSFET switching transients. For reliable operation, the switch node ( $V_{SW}$ ) to ground voltage must remain at or below the *Absolute Maximum Ratings*.
- (2) Measurement made with six 10- $\mu\text{F}$  (TDK C3216X7R1C106KT or equivalent) ceramic capacitors across  $V_{IN}$  to  $P_{GND}$  pins.
- (3) System conditions as defined in Note 2. Peak output current is applied for  $t_p = 50\ \mu\text{s}$ .

## 6.4 Thermal Information

$T_A = 25^\circ\text{C}$  (unless otherwise stated)

THERMAL METRIC		MIN	TYP	MAX	UNIT
$\theta_{JC}$	Thermal resistance, junction-to-case (top of package)		7.4		$^\circ\text{C}/\text{W}$
$\theta_{JB}$	Thermal resistance, junction-to-board <sup>(1)</sup>		2.2		$^\circ\text{C}/\text{W}$
$\Psi_{JT}$	Junction-to-top characterization parameter		0.9		$^\circ\text{C}/\text{W}$

- (1)  $\theta_{JB}$  is determined with the device mounted on a 1-in<sup>2</sup> (6.45-cm<sup>2</sup>), 2-oz (0.071-mm) thick Cu pad on a 1.5-in × 1.5-in, 0.06-in (1.52-mm) thick FR4 board based on hottest board temperature within 1 mm of the package.

## 7 Application Schematic

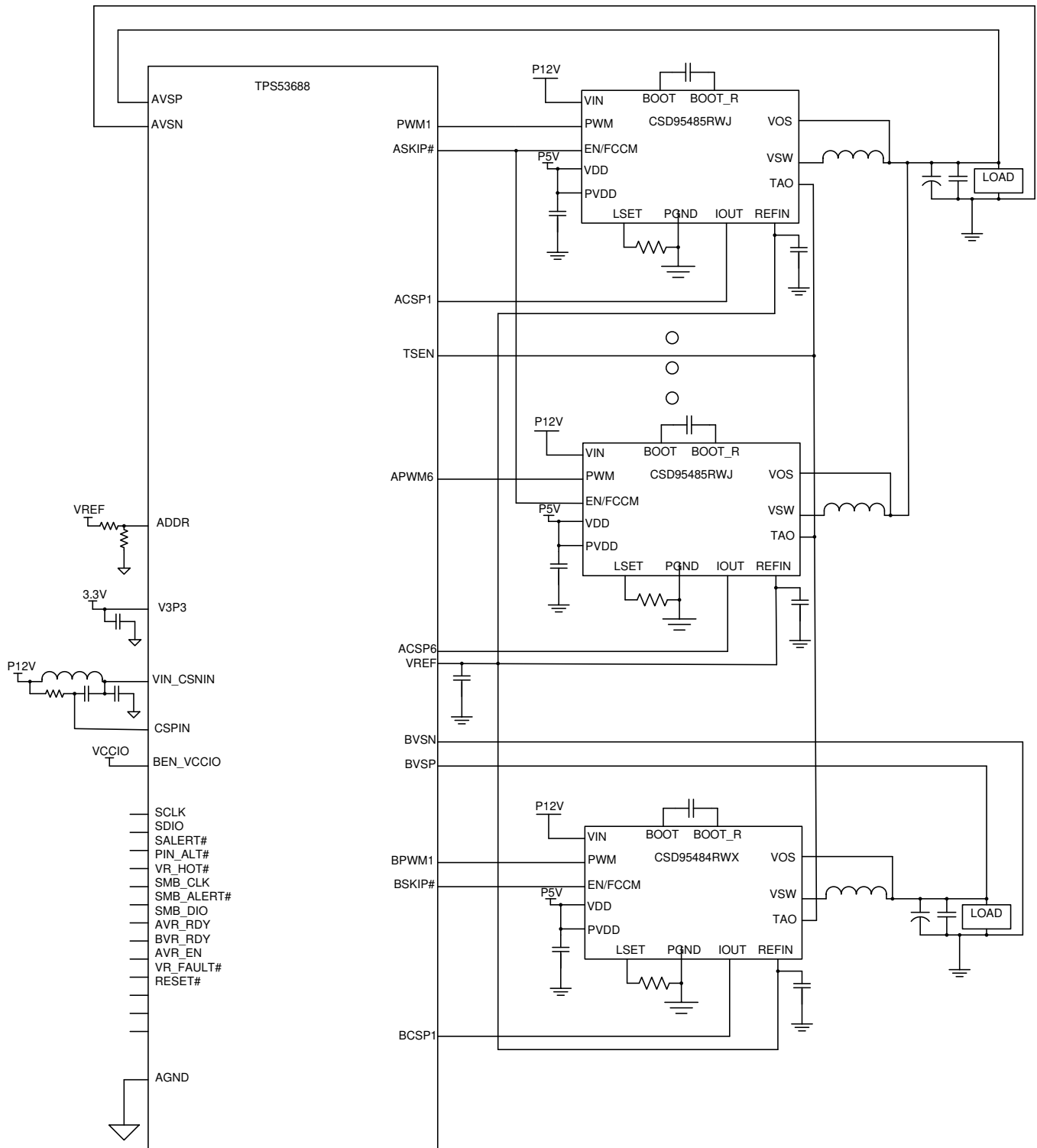

Figure 1. Application Schematic

Note: The schematic in Figure 1 is a conceptual drawing only. Actual designs may require additional components not shown.

## 8 器件和文档支持

### 8.1 商标

NexFET is a trademark of Texas Instruments.  
All other trademarks are the property of their respective owners.

### 8.2 静电放电警告



这些装置包含有限的内置 ESD 保护。存储或装卸时，应将导线一起截短或将装置放置于导电泡棉中，以防止 MOS 门极遭受静电损伤。

### 8.3 Glossary

[SLYZ022](#) — *TI Glossary*.

This glossary lists and explains terms, acronyms, and definitions.

## 9 机械、封装和可订购信息

以下页面包含机械、封装和可订购信息。这些信息是指定器件的最新可用数据。数据如有变更，恕不另行通知，且不会对此文档进行修订。如需获取此数据表的浏览器版本，请查阅左侧的导航栏。

### 9.1 机械制图

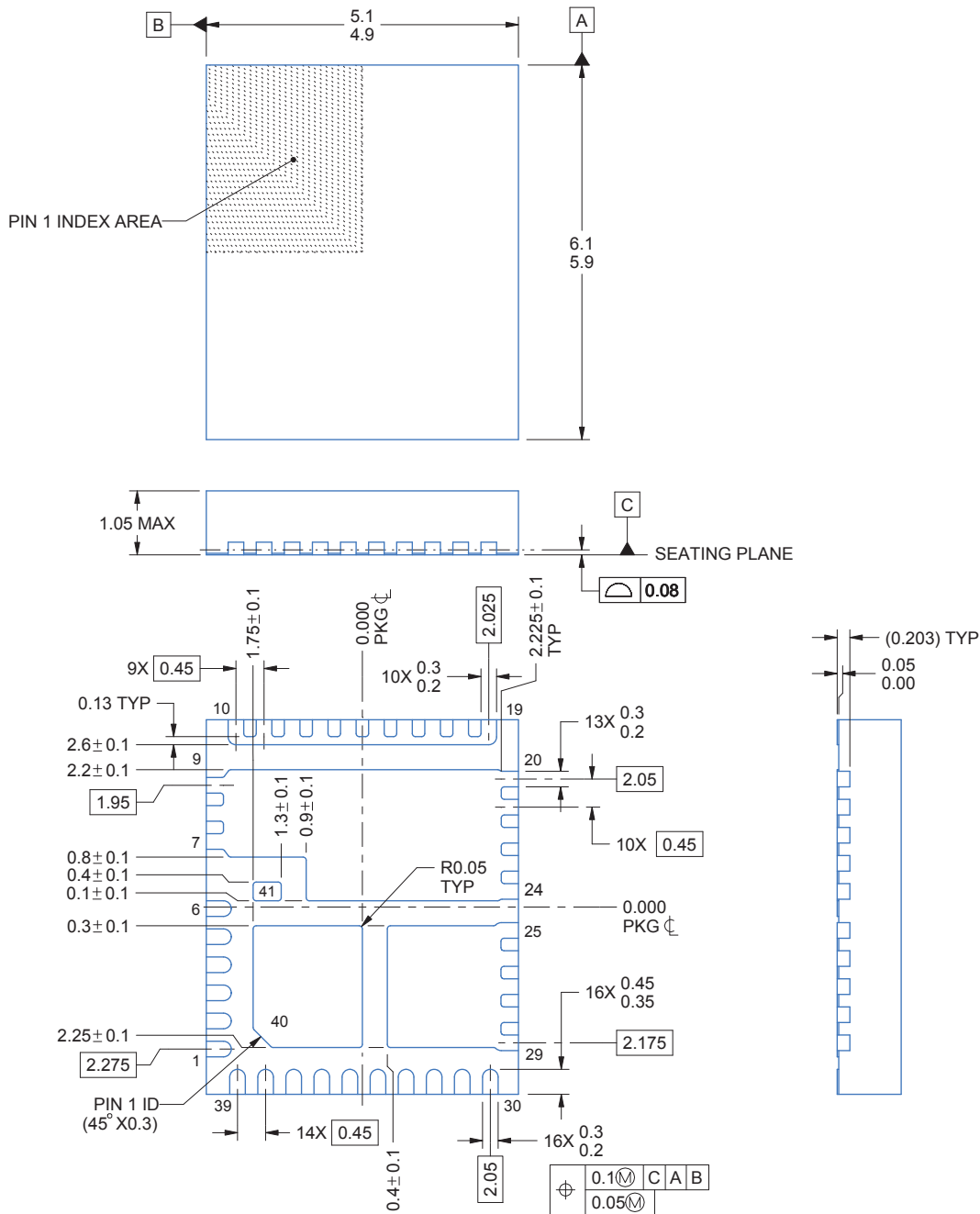



### 9.3 建议模版开孔

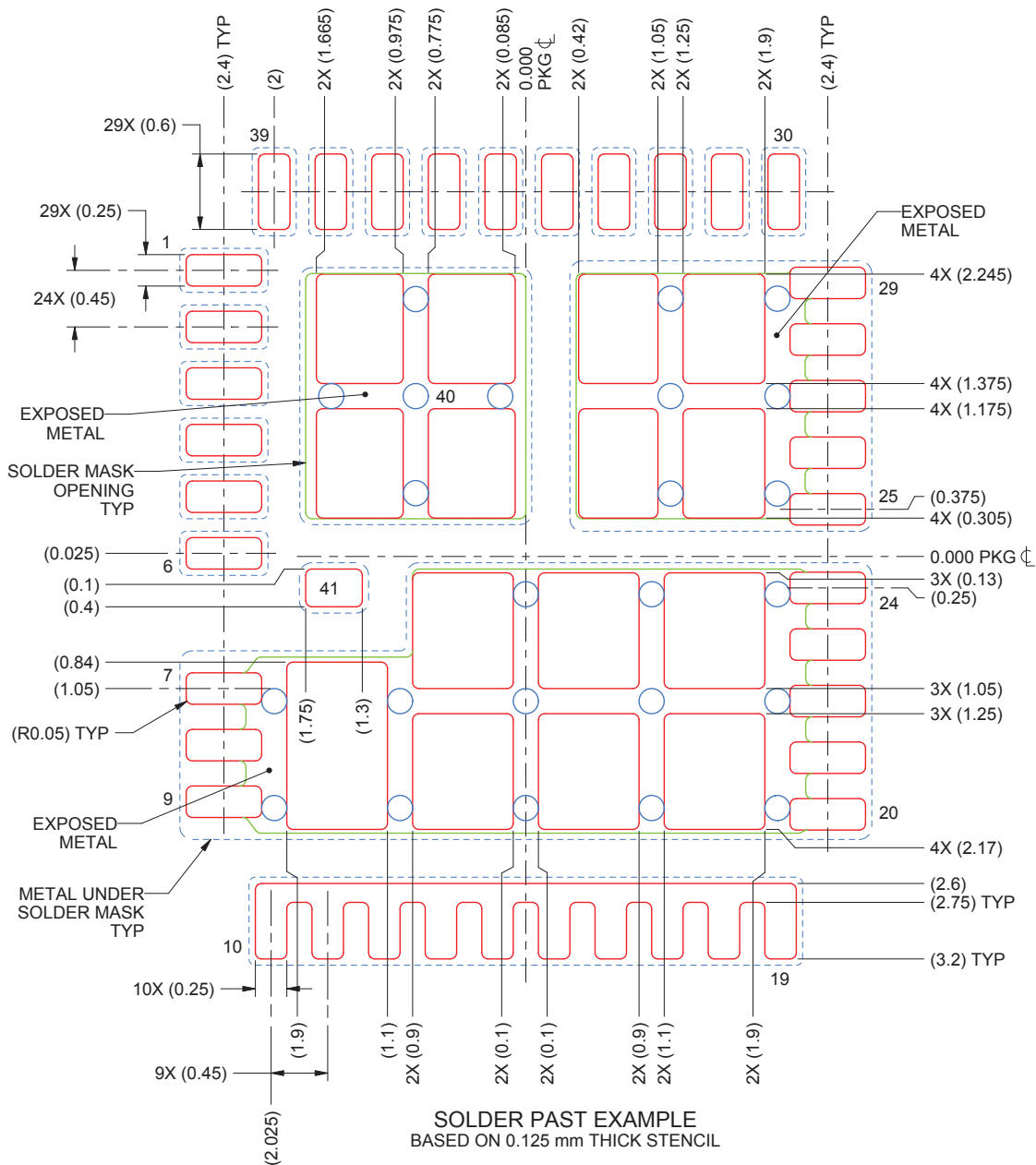

1. 所有线性尺寸的单位均为毫米。括号中的任何尺寸仅供参考。尺寸和公差值符合 ASME Y14.5M 标准。
2. 本图如有变更，恕不另行通知。
3. 具有漏斗形壁和圆角的激光切割孔可提供最佳的锡膏脱离。IPC-7525 可能提供替代设计建议。

**PACKAGING INFORMATION**

Orderable part number	Status (1)	Material type (2)	Package   Pins	Package qty   Carrier	RoHS (3)	Lead finish/ Ball material (4)	MSL rating/ Peak reflow (5)	Op temp (°C)	Part marking (6)
<a href="#">CSD95485RWJ</a>	NRND	Production	VQFN-CLIP (RWJ)   41	2500   LARGE T&R	ROHS Exempt	NIPDAU   SN	Level-2-260C-1 YEAR	-55 to 150	95485RWJ
CSD95485RWJ.Z	NRND	Production	VQFN-CLIP (RWJ)   41	2500   LARGE T&R	ROHS Exempt	NIPDAU	Level-2-260C-1 YEAR	-55 to 150	95485RWJ
<a href="#">CSD95485RWJT</a>	NRND	Production	VQFN-CLIP (RWJ)   41	250   SMALL T&R	ROHS Exempt	NIPDAU   SN	Level-2-260C-1 YEAR	-55 to 150	95485RWJ
CSD95485RWJT.Z	NRND	Production	VQFN-CLIP (RWJ)   41	250   SMALL T&R	ROHS Exempt	NIPDAU	Level-2-260C-1 YEAR	-55 to 150	95485RWJ

(1) **Status:** For more details on status, see our [product life cycle](#).

(2) **Material type:** When designated, preproduction parts are prototypes/experimental devices, and are not yet approved or released for full production. Testing and final process, including without limitation quality assurance, reliability performance testing, and/or process qualification, may not yet be complete, and this item is subject to further changes or possible discontinuation. If available for ordering, purchases will be subject to an additional waiver at checkout, and are intended for early internal evaluation purposes only. These items are sold without warranties of any kind.

(3) **RoHS values:** Yes, No, RoHS Exempt. See the [TI RoHS Statement](#) for additional information and value definition.

(4) **Lead finish/Ball material:** Parts may have multiple material finish options. Finish options are separated by a vertical ruled line. Lead finish/Ball material values may wrap to two lines if the finish value exceeds the maximum column width.

(5) **MSL rating/Peak reflow:** The moisture sensitivity level ratings and peak solder (reflow) temperatures. In the event that a part has multiple moisture sensitivity ratings, only the lowest level per JEDEC standards is shown. Refer to the shipping label for the actual reflow temperature that will be used to mount the part to the printed circuit board.

(6) **Part marking:** There may be an additional marking, which relates to the logo, the lot trace code information, or the environmental category of the part.

Multiple part markings will be inside parentheses. Only one part marking contained in parentheses and separated by a "-" will appear on a part. If a line is indented then it is a continuation of the previous line and the two combined represent the entire part marking for that device.

**Important Information and Disclaimer:** The information provided on this page represents TI's knowledge and belief as of the date that it is provided. TI bases its knowledge and belief on information provided by third parties, and makes no representation or warranty as to the accuracy of such information. Efforts are underway to better integrate information from third parties. TI has taken and continues to take reasonable steps to provide representative and accurate information but may not have conducted destructive testing or chemical analysis on incoming materials and chemicals. TI and TI suppliers consider certain information to be proprietary, and thus CAS numbers and other limited information may not be available for release.

In no event shall TI's liability arising out of such information exceed the total purchase price of the TI part(s) at issue in this document sold by TI to Customer on an annual basis.

## 重要通知和免责声明

TI“按原样”提供技术和可靠性数据（包括数据表）、设计资源（包括参考设计）、应用或其他设计建议、网络工具、安全信息和其他资源，不保证没有瑕疵且不做任何明示或暗示的担保，包括但不限于对适销性、某特定用途方面的适用性或不侵犯任何第三方知识产权的暗示担保。

这些资源可供使用 TI 产品进行设计的熟练开发人员使用。您将自行承担以下全部责任：(1) 针对您的应用选择合适的 TI 产品，(2) 设计、验证并测试您的应用，(3) 确保您的应用满足相应标准以及任何其他功能安全、信息安全、监管或其他要求。

这些资源如有变更，恕不另行通知。TI 授权您仅可将这些资源用于研发本资源所述的 TI 产品的相关应用。严禁以其他方式对这些资源进行复制或展示。您无权使用任何其他 TI 知识产权或任何第三方知识产权。您应全额赔偿因在这些资源的使用中对 TI 及其代表造成的任何索赔、损害、成本、损失和债务，TI 对此概不负责。

TI 提供的产品受 [TI 的销售条款](#) 或 [ti.com](#) 上其他适用条款/TI 产品随附的其他适用条款的约束。TI 提供这些资源并不会扩展或以其他方式更改 TI 针对 TI 产品发布的适用的担保或担保免责声明。

TI 反对并拒绝您可能提出的任何其他或不同的条款。

邮寄地址：Texas Instruments, Post Office Box 655303, Dallas, Texas 75265  
版权所有 © 2025，德州仪器 (TI) 公司